

ROLLING SERVICE DOORS

4

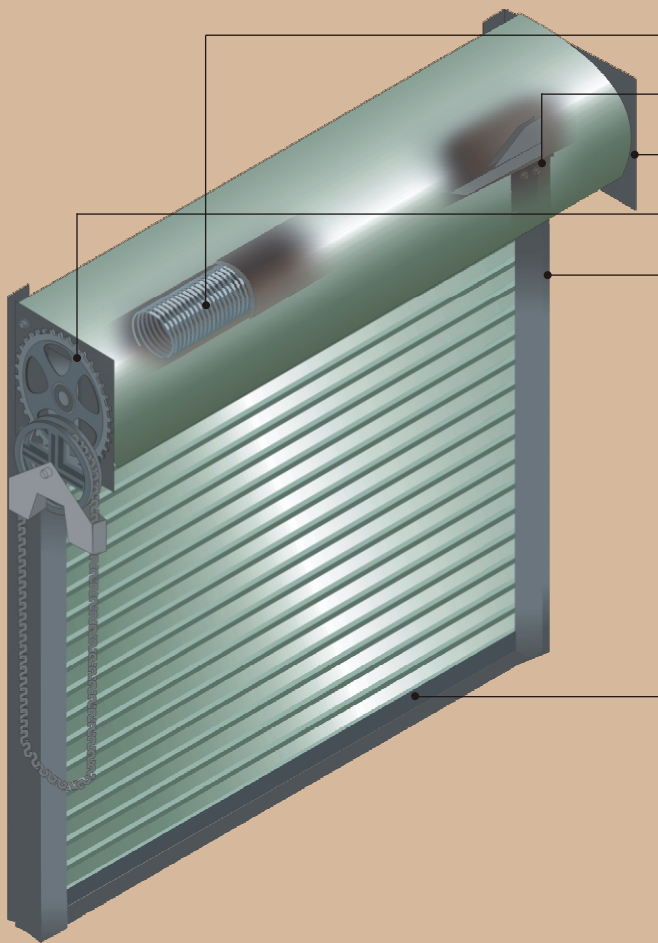

Built to Last

- Oil Tempered Torsion Springs Designed for 50,000 Life Cycles
- Cast Iron Stops
- 1/4" Thick (Minimum) Steel Plate Brackets
- Heavy Duty Cast Gears
- Structural Angle Guides and Bottom Bar

Choice of Finishes

- FinalCote™ (Standard) (Tan, White, or Gray)
- ColorCote™
- 180 Standard Colors (Optional)
- Unlimited Custom Colors (Optional)
- Stainless Steel #4 Polish
- Aluminum (Mill or Clear Anodized)

Choice of Operation

- Push-Up - limit 80 square feet or 8' high
- Chain
- Crank
- Motor

Determine Dimensions For Specific Door Size

1. From chart below select proper Area Number for width and height of door.
2. Refer to Selection Chart for dimensions.

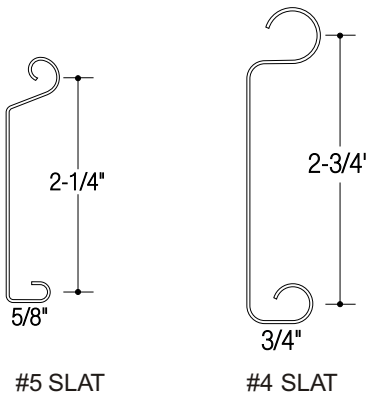
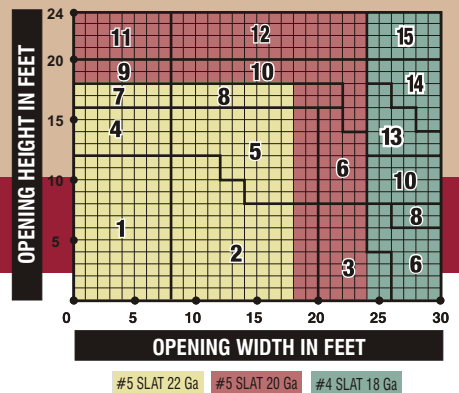

SLAT SELECTION

#5 Slat	22 and 20 Gauge Steel
	22 and 20 Gauge Stainless Steel #4 Finish
	.040" Aluminum Mill or Clear Anodized Finish
#4 Slat	18 Gauge Steel
	20 Gauge Stainless Steel #4 Finish
	.050" Aluminum Mill or Clear Anodized

GAUGE SELECTION

#5 Slat 22 Gauge Steel or Stainless Steel	Max. Door Width 18' 0"
#5 Slat 20 Gauge Steel or Stainless Steel	Max. Door Width 24' 0"
#5 Slat .040 Aluminum	Max. Door Width 20' 0"
#4 Slat 18 Gauge Steel	Doors Over 24' 0"
#4 Slat 20 Gauge Stainless Steel	Max. Door Width 30' 0"
#4 Slat .050 Aluminum	Max. Door Width 30' 0"

AREA	COMPONENT DIMENSIONS						
	A	B	C	D	W	X	Y
1	13.0"	14.0"	6.0"	9.5"	2.5"	2.5"	2.5"
2	13.0"	14.0"	6.5"	9.5"	2.5"	3.0"	2.5"
3	13.0"	14.0"	6.5"	9.5"	2.5"	3.0"	3.0"
4	15.0"	16.0"	6.0"	9.5"	2.5"	2.5"	2.5"
5	15.0"	16.0"	6.5"	9.5"	2.5"	3.0"	2.5"
6	16.0"	16.0"	6.5"	9.5"	2.5"	3.0"	3.0"
7	16.0"	17.0"	6.0"	9.5"	2.5"	2.5"	3.0"
8	16.0"	17.0"	6.5"	9.5"	2.5"	3.0"	3.0"
9	18.0"	19.0"	6.0"	9.5"	2.5"	2.5"	3.5"
10	18.0"	19.0"	6.5"	9.5"	2.5"	3.0"	3.5"
11	20.0"	21.0"	6.0"	9.5"	2.5"	2.5"	3.5"
12	20.0"	21.0"	6.5"	9.5"	2.5"	3.0"	3.5"
13	20.0"	21.0"	6.5"	9.5"	3.0"	3.0"	4.0"
14	22.0"	23.0"	6.5"	9.5"	3.0"	3.0"	5.0"
15	24.0"	25.0"	6.5"	9.5"	3.0"	3.0"	5.0"

E = 2 1/2" standard; 3 1/2" with astragal; 5 1/2" with Featheredge

Dimensions are based on #5 Slat 22 ga. for doors to 18'0" wide, #5 Slat 20 ga. for doors 18'1" to 24'0" wide and #4 Slat 18 ga. for doors over 24'0" wide. Use of other slats and gauges may increase the dimensions shown.



Dimensions shown are for initial design. For final design and specifications, visit cooksondoor.com.

Weatherbar® Door

For exterior walls that will be exposed to the elements, we recommend Cookson's Weatherbar Door. This fully weatherstripped rolling door gives excellent protection against wind-driven rains and dust.



Hard Rock Park
- Myrtle Beach, SC

SERVICE DOOR MODEL NUMBERS

	MOUNTING		OPERATION			
	Face of Wall	Between Jamb	Push-Up	Chain	Crank	Motor
FP	●		●			
JP		●	●			
FC	●			●		
JC		●		●		
FK	●				●	
JK		●			●	
FCM	●					●
JCM		●				●

Standard Features Exceed Industry Standards

At The Cookson Company we only build one kind of Rolling Service Door, heavy duty. Every service door we build includes: 50,000 life cycle design, structural angle guides and bottom bar, cast iron gears and stops, fabricated steel brackets, 20 psf windloading and our exclusive FinalCote finish. The Cookson family has spent 70 years manufacturing premium rolling door products that have endured the test of time.

Effortless Operation

Cookson doors are recognized in the industry as being the easiest to operate. Premium ball bearings, balance designs, and precision construction ensure efficient, trouble-free use with minimal maintenance. Door size, building design and operational requirements should determine the operator type.

TYPICAL DETAILS

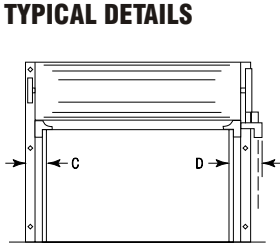

SERVICE DOOR ELEVATION

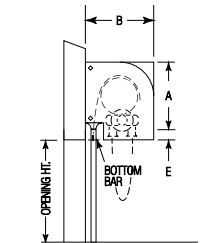

CHAIN OPERATED SECTION

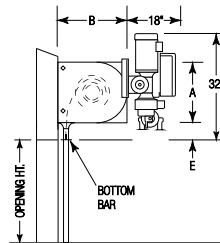

MOTOR (GEARHEAD) SECTION

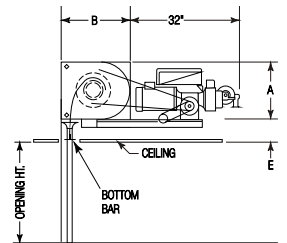

MOTOR (GEARHEAD) SECTION
Alternate Mount

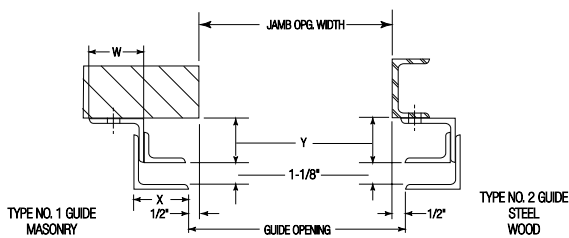

FACE OF WALL GUIDES

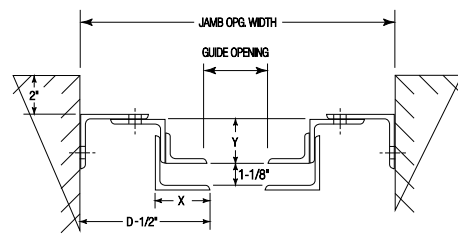

BETWEEN JAMB GUIDES