



# HPL152

Semi Electric Pallet Truck 1.5T

**LI-ION**  
TECHNOLOGY

**EP EQUIPMENT CO.,LTD**  
[www.ep-ep.com](http://www.ep-ep.com)



## ▣ FEATURE

### ■ Smart lithium battery

It is equipped with lithium battery of 24V/20A.h, which is much lighter and longer battery life. It has an internal charger, so it can be used even when charged. It saves worries about the endurance and there is no need of special charging area.

### ■ Newly designed handle head

Its structural layout fits principles of ergonomics and it is operated simply and comfortably.

### ■ Manual lifting and lowering

Lifting speed is 10 mm/time, its operation is simple and controllable.

### ■ Pass market tests of safety and reliability

HPL152 has 10-year market-tested components.

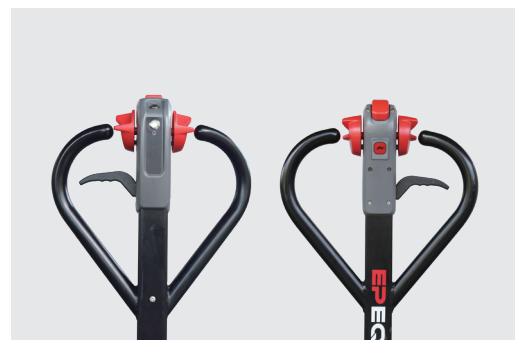

# Semi Electric Pallet Truck 1.5T

## HPL152

Distinguishing mark				
1.1	Manufacturer			EP
1.2	Model designation			HPL152
1.3	Drive unit			Battery
1.4	Operator type			Walkie
1.5	rated capacity	Q	kg	1500
1.6	Load center distance	c	mm	600
1.8	Load distance	x	mm	883/946
1.9	Wheelbase	y	mm	1105/1168
Weight				
2.1	Service weight (include battery)		kg	130
2.2	Axle loading, laden driving side/loading side		kg	558/1172
2.3	Axle loading, unladen driving side/loading side		kg	84/46
Types,Chassis				
3.1	Tyre type driving wheels/loading wheels			PU/ PU
3.2	Tyre size, driving wheels (diameter×width)		mm	Φ210x70
3.3	Tyre size, loading wheels (diameter×width)		mm	2x Φ78x60 (Φ78x88)
3.4	Tyre size, caster wheels (diameter×width)		mm	/
3.5	Wheels, number driving, caster/loading (x=drive wheels)		mm	1x /4 (1x /2)
3.6	Track width, front,driving side	b <sub>10</sub>	mm	/
3.7	Track width,rear,loading side	b <sub>11</sub>	mm	390
Dimensions				
4.4	Lift height	h <sub>3</sub>	mm	115
4.9	Height drawbar in driving position min./max.	h <sub>14</sub>	mm	638/1275
4.15	Lowered height	h <sub>13</sub>	mm	80
4.19	Overall length	l <sub>1</sub>	mm	1518
4.20	Length to face of forks	l <sub>2</sub>	mm	381
4.21	Overall width	b <sub>1</sub> / b <sub>2</sub>	mm	548
4.22	Fork dimensions	s/ e/ l	mm	50/150/1150
4.25	Outside width of the forks	b <sub>5</sub>	mm	540
4.32	Ground clearance, center of wheelbase	m <sub>2</sub>	mm	30
4.34.1	Aisle width for pallets 1000 × 1200 crossways	Ast	mm	1612
4.34.2	Aisle width for pallets 800 × 1200 lengthways	Ast	mm	1812
4.35	Turning radius	Wa	mm	1358
Performance data				
5.1	Travel speed, laden/ unladen	km/ h	km/h	3.5/4
5.2	Lifting speed, laden/ unladen		m/ s	10mm/time
5.3	Lowering speed, laden/ unladen		m/ s	Manual lowering
5.8	Max. gradeability, laden/unladen		%	5/10
5.10	Service brake type			Electromagnetic
Electric-engine				
6.1	Drive motor rating S2 60 min		kW	0.75
6.2	Lift motor rating at S3 15%		kW	Manual lifting
6.3	The maximum allowed size battery		mm	193*81*300 (Li-ion)
6.4	Battery voltage/nominal capacity K5		V/AH	24V/20Ah
6.5	Battery weight		kg	5*1
Addition data				
8.1	Type of drive control			DC
10.5	Steering type			Mechanical
10.7	Sound pressure level at the driver's ear		dB (A)	74

If there are improvements of technical parameters or configurations, no further notice will be given.  
The diagram shown may contain non-standard configurations.

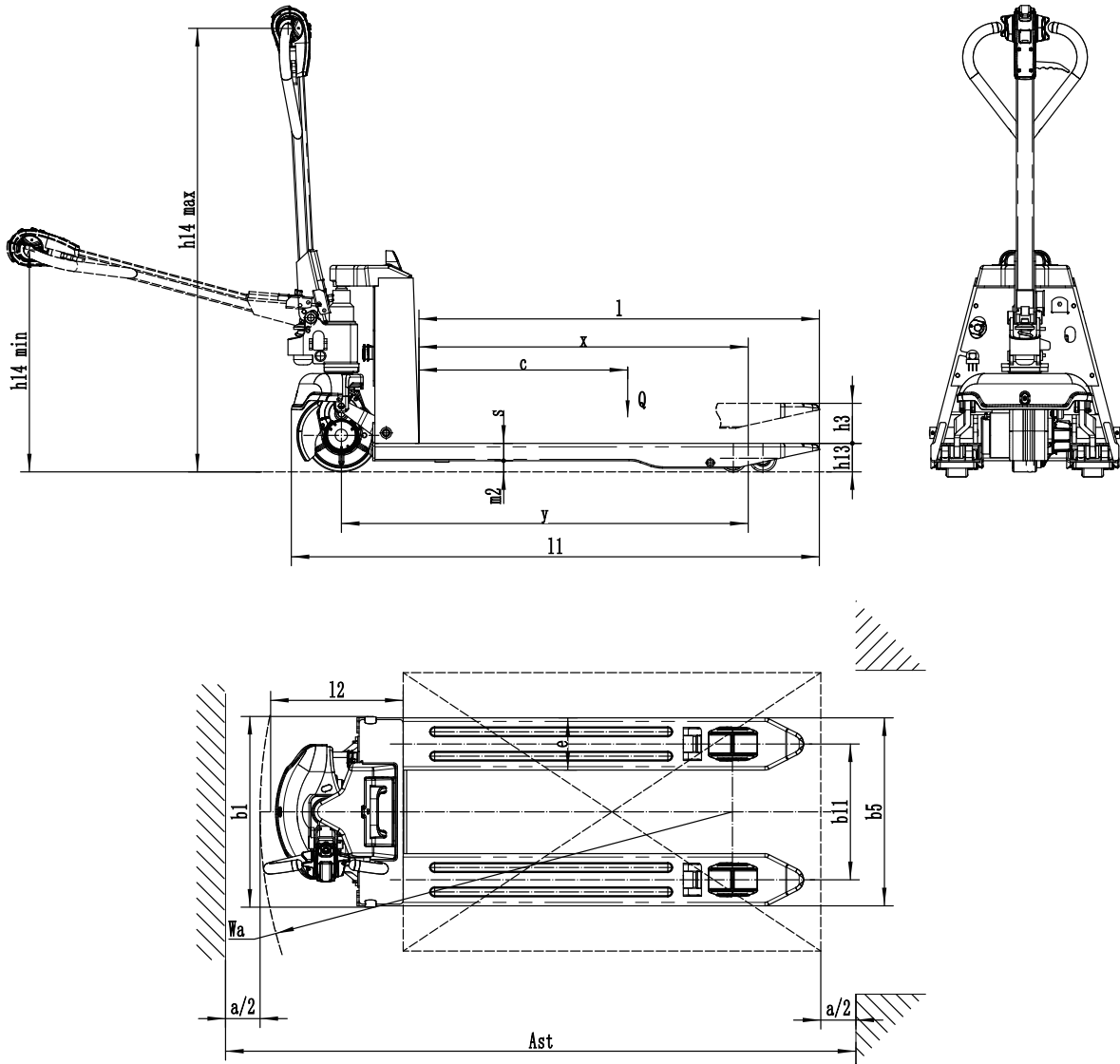

## Option

Options	HPL152
Fork length	○ 800/1000/1150/1220/1350/1500mm
Fork width	○ 540/685mm
Single load wheel	○
Fork lowered height	● 80mm
Driving wheel	○ PU wheel with Pattern
Balance wheel	—
Battery capacity	—
Lateral change battery	—
Battery indicator with hour meter	—
half speed function in turning	—
Special backrest	—
Water proof	—
Electronic scale	—
Vertical handler working	○
external charger	○

Note: ● standard ○ option — NA